

**□□ Dolby B Type Noise Reduction System with Playback Equalizer****Description**

The CXA1580Q is an IC designed for use in car stereos. Functions include Dolby B type noise reduction, playback equalizer and interval detection between tracks (MUSIC SENSOR) into a single chip.

**Features**

- Few external parts
- Forward/Reverse head switching
- 3-input selector switch (TAPE, CD, RADIO)
- Small package (40-pin QFP)
- Dolby B type noise reduction and playback equalizer into a single chip
- Same pin configuration as Dolby B/C type noise reduction system (CXA1581)
- Interval detection level between tracks can be set by external resistors/capacitors (2 modes).

**Applications**

- Car stereos
- Stereo cassette deck players (playback only)

**Structure**

Bipolar silicon monolithic IC

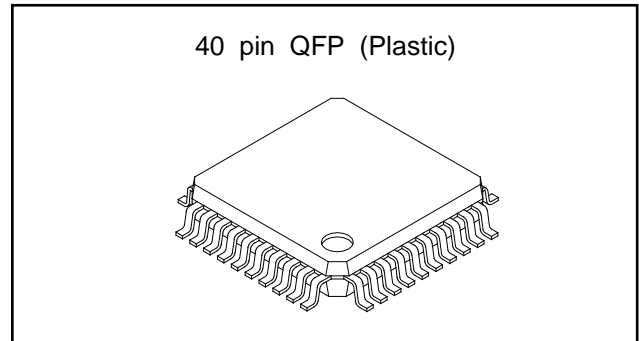
**Absolute Maximum Ratings (Ta=25°C)**

• Supply voltage	V <sub>CC</sub>	12	V
• Operating temperature	T <sub>opr</sub>	-40 to +85	°C
• Storage temperature	T <sub>stg</sub>	-65 to +150	°C
• Allowable power dissipation	P <sub>D</sub>	430	mW

**Recommended Operating Condition**

Supply voltage	V <sub>CC</sub>	6.5 to 11	V
----------------	-----------------	-----------	---

\* "Dolby" and the double D symbols are trademarks of Dolby Laboratories Licensing Corporation.

Sony reserves the right to change products and specifications without prior notice. This information does not convey any license by any implication or otherwise under any patents or other right. Application circuits shown, if any, are typical examples illustrating the operation of the devices. Sony cannot assume responsibility for any problems arising out of the use of these circuits.

Block Diagram and Pin Configuration

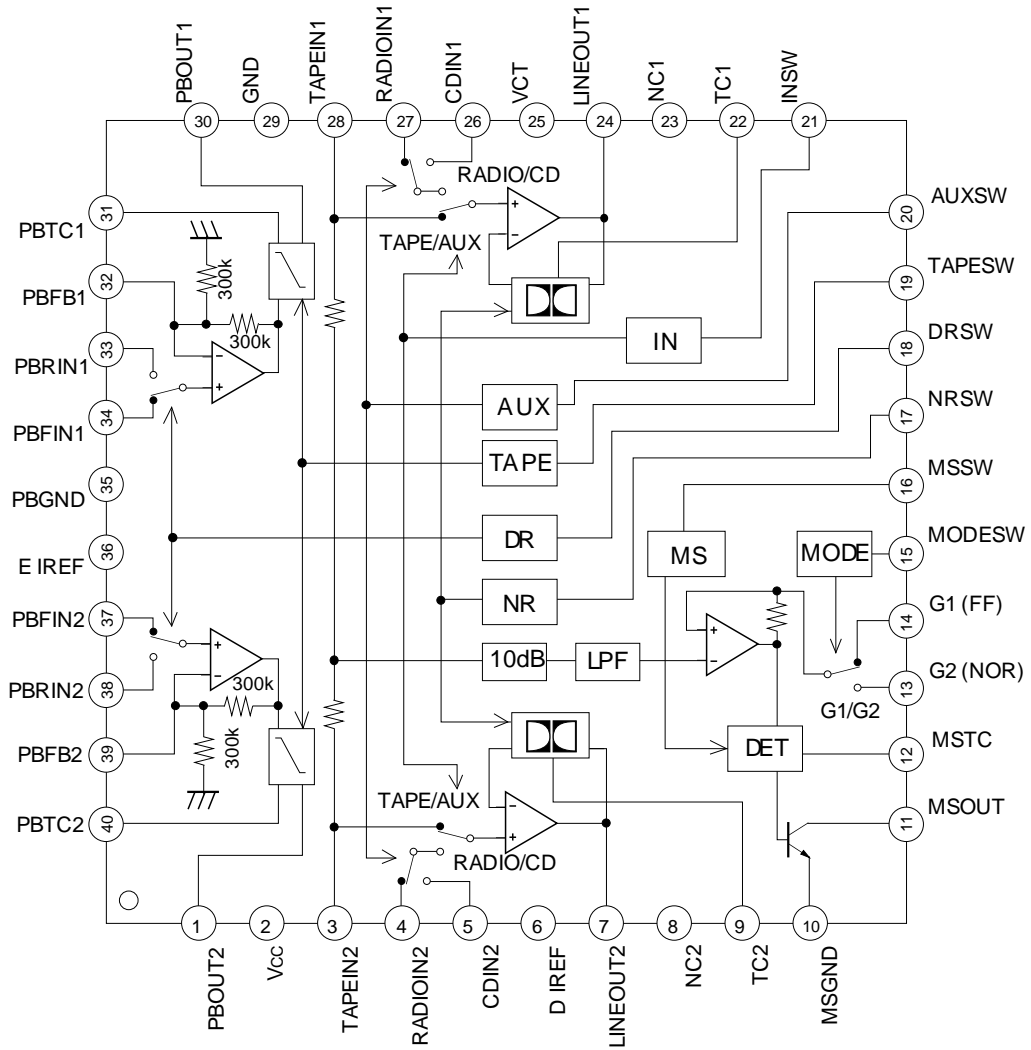

Pin Description

(Ta=25°C, Vcc=8.0V, no signal)

Pin No.	Symbol	DC value	I/O resistance	Equivalent circuit	Description
1 30	PBOUT	2.8V	—	Refer to Page 6.	PBEQ output
32 39	PBFB	1.4V	150kΩ		PBEQ feedback
33 34 37 38	PBIN	0V	70kΩ		PBEQ input
2	Vcc	8.0V	—	_____	Power supply
10 29 35	GND MSGND PBGND	0.0V	—	_____	Ground
31 40	PBTC	—	—		PBEQ capacitance
36	E IREF	1.25V	—		Connection of reference current setting resistor for PBEQ block.
11	MSOUT	0.0V for signal detection; 5.0V for no signal detection	—		MS output

Pin No.	Symbol	DC value	I/O resistance	Equivalent circuit	Description
12	MSTC	Approx. 1.4V for signal detection; 5.0V for no signal detection	—		Connection of MS detection time constant
13 14	G2(NOR) G1(FF)	4.0V	—		MS feedback
3 28	TAPEIN	4.0V	40kΩ		TAPE input
4 27	RADIOIN				RADIO input
5 26	CDIN				CD input
6	D IREF	1.25V	—		Connection of reference current setting resistor for Dolby block
7 24	LINEOUT	4.0V	—		Line output

Pin No.	Symbol	DC value	I/O resistance	Equivalent circuit	Description
9 22	TC	0.3V	—		Connection of Dolby detection capacitor
15 17 18 19 20 21	MODESW NRSW DRSW TAPESW AUXSW INSW	—	—		Refer to Page 6.
16	MSSW	—	—		Refer to Page 6.
25	VCT	4.0V	—		Vcc/2 output
8 23	NC	—	—		No connection.

\* PBOUT, PBFB, PBIN equivalent circuit

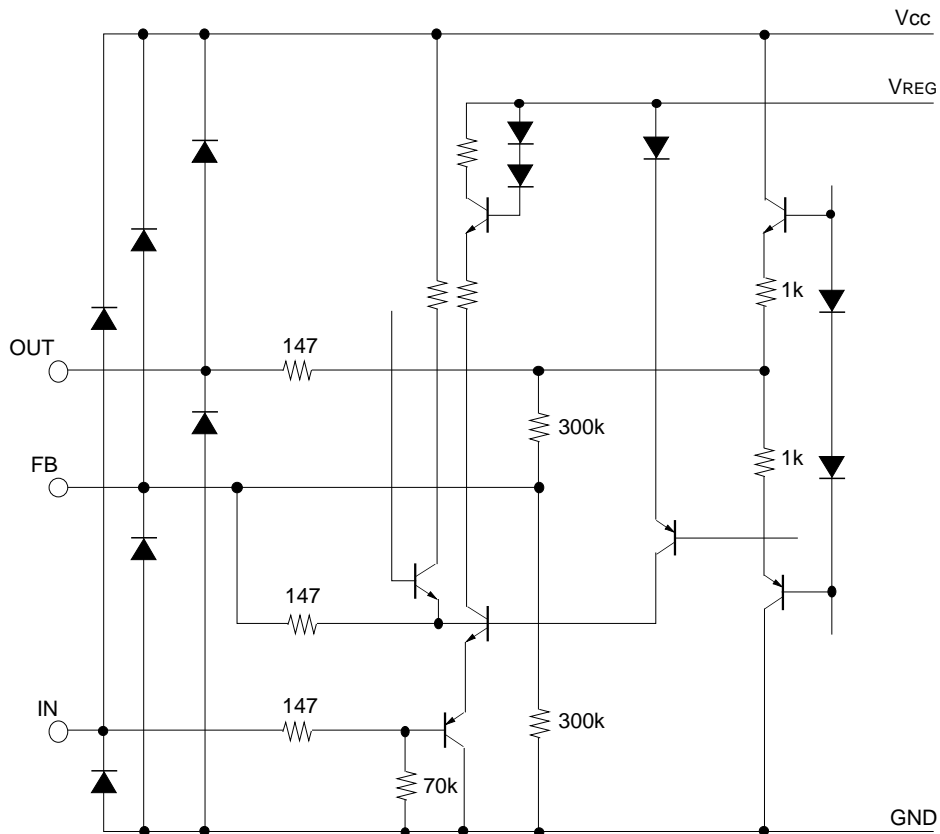

\* Description for SW pins

- MODESW - Switching of MS signal detection/blank detection  
High: G1 (signal detection); Low: G2 (blank detection)
- NRSW - Switching of Dolby B type noise reduction ON/OFF  
High: noise reduction OFF; Low: Dolby B
- DRSW - Switching of tape rotation  
High: reverse; Low: forward
- TAPESW - Switching of HIGH/NORMAL tape  
High: NORMAL tape; Low: HIGH tape
- AUXSW - Switching of CD/RADIO in the AUX mode  
High: CD; Low: RADIO
- INSW - Switching of TAPE/AUX  
High: TAPE; Low: AUX
- MSSW - Switching of MS ON/OFF  
High: MS ON; Low: MS OFF

## Electrical Characteristics

(Ta=25°C, Vcc=8.0V, RL: output load resistance, Rg: head equivalent impedance)

Item	Symbol	Measurement conditions* (input pin, input level, frequency etc.)	Min.	Typ.	Max.	Unit
Current consumption	Icc	No signal	9.0	12.4	16.0	mA
Dolby block (Dolby level -6dBm=0dB)						
TAPEIN input sensitivity	VTIN	LINEOUT= 0 dB 1kHz	-32.0	-30.0	-28.0	dBm
RADIOIN input sensitivity	VRIN	LINEOUT= 0 dB 1kHz				
CDIN input sensitivity	VCIN	LINEOUT= 0 dB 1kHz				
Decode boost 1	BP1	TAPEIN 500Hz NR-ON Vlo=-25dB	1.4	2.9	4.4	dB
Decode boost 2	BP2	TAPEIN 2kHz NR-ON Vlo=-25dB	5.5	6.4	8.5	
Decode boost 3	BP3	TAPEIN 5kHz NR-ON Vlo=-25dB	3.9	5.2	6.9	
Decode boost 4	BP4	TAPEIN 10kHz NR-ON Vlo=-40dB	9.7	10.4	11.9	
Decode boost 5	BP5	TAPEIN 10kHz NR-ON Vlo=0dB	-1.1	0.4	1.9	
TAPEIN total harmonic distortion 1	THD1	TAPEIN -20dBm 1kHz RL=2.7kΩ	—	0.02	0.2	%
TAPEIN total harmonic distortion 2	THD2	TAPEIN -20dBm 1kHz NRON RL=2.7kΩ				
RADIOIN total harmonic distortion	THD3	RADIOIN -20dBm 1kHz RL=2.7kΩ				
CDIN total harmonic distortion	THD4	CDIN -20dBm 1kHz RL=2.7kΩ				
Decode S/N ratio	SN1	No signal NR ON CCIR/ARM filter	77.0	82.8	—	dB
Signal handling	VOMAX1	1kHz THD=1% RL=2.7kΩ	13.0	14.4	—	dB
Cross talk TAPEIN→CDIN	CT1	TAPEIN -24dBm 1kHz	—	-87	-65	dB
Cross talk RADIOIN→CDIN	CT2	RADIOIN -24dBm 1kHz	—	-86	-60	
Cross talk TAPEIN 1ch→2ch	CT3	TAPEIN -24dBm 1kHz	—	-67	-55	
LINEOUT offset voltage	Vos1	No signal	3.9	4.0	4.1	V
Playback equalizer amplifier block						
120μs FWD frequency characteristics	PBREF	PBFIN 315Hz -70dBm VPBO=0dB	-27.0	-25.0	-23.0	dBm
120μs FWD frequency characteristics	F120F	PBFIN 2.7kHz -58.5dBm for 315Hz	-1.5	0.0	1.5	
70μs FWD frequency characteristics	F70F	PBFIN 4.5kHz -53.8dBm for 315Hz				
120μs RVS frequency characteristics	F120R	PBRIN 315Hz -70dBm for 315Hz	-1.0	0.0	1.0	dBm
Signal handling	VOMAX2	PBFIN 1kHz THD=1% RL=2.7kΩ	-10.0	-3.0	—	
Total harmonic distortion	THD5	PBFIN 1kHz -52dBm RL=2.7kΩ	—	0.07	0.5	%
S/N ratio	SN2	No signal "A" weighting filter	55.0	58.0	—	dB
Output offset voltage	Vos2	No signal Rg=2.2kΩ	2.4	2.8	3.2	V
Cross talk between channels	CT4	TAPEIN 1kHz -42dBm		-78	-70	dB
Cross talk between RVS and FWD	CT5			-75	-65	
Interval detection between tracks (MUSIC SENSOR) block						
Signal detection level 1	VMS1	TAPEIN 5kHz AMS ON (G1 mode)	—	-35	—	dBm
Signal detection level 2	VMS2	TAPEIN 5kHz AMS ON (G2 mode)	—	-55	—	
MS output leak current	IoH	TAPEIN 5kHz -10dBm, 5V applied to AMSOUT	—	0.0	1.0	μA
MS output saturation voltage	Vol	TAPEIN 5kHz -30dBm, 1mA applied to AMSOUT	—	0.0	1.0	V
Logic voltage	VIL	AUXSW, MODESW, INSW, MSSW,	0.0	—	1.0	V
	VIH	TAPESW, NRSW, DRSW	2.5	—	Vcc	

\*120μs, FWD mode, NR OFF, MS OFF unless otherwise specified.

## Description of Operation

Operation mode control (INSW, AUXSW, TAPESW, DRSW, NRSW, MSSW, MODESW)

The CXA1580Q has built in electronic switch circuits and the operations are controlled by the direct current applied to each SW pin. The operation mode state for each switch is shown in the table below.

SW	Function for Low input	Function for High input
INSW	AUX (CD/RADIO) IN	TAPE IN
AUXSW	RADIO	CD
TAPESW	70 $\mu$ S	120 $\mu$ s
DRSW	PB FWD	PB RVS
NRSW	DOLBY B NR	NR OFF
MSSW	MS OFF	MS ON
MODESW	G2(NOR) MODE	G1(FF) MODE

Click noise can be reduced by the external CR time constant circuit for NR SW switching.



Electrical Characteristics Measurement Circuit

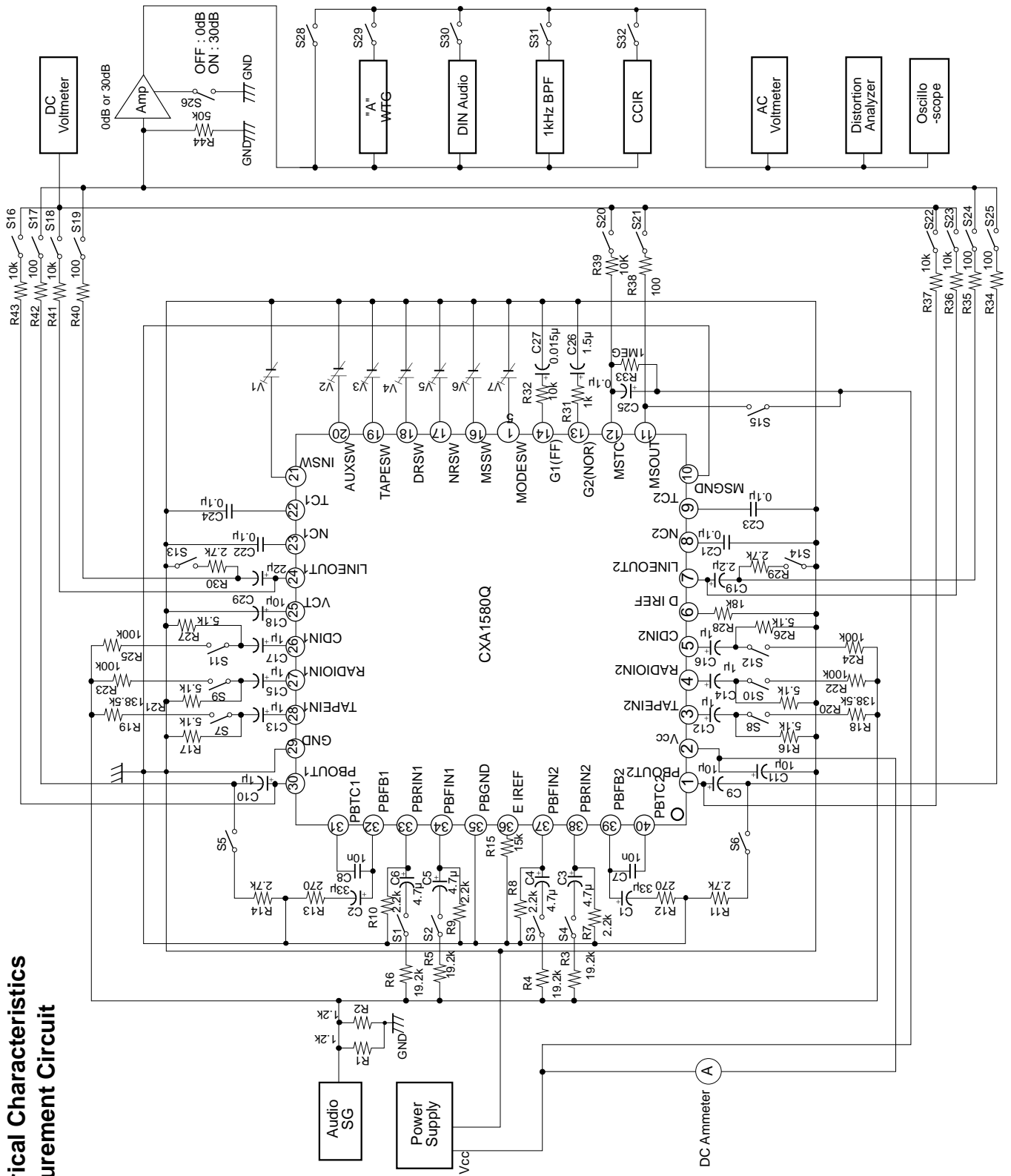

Application Circuit

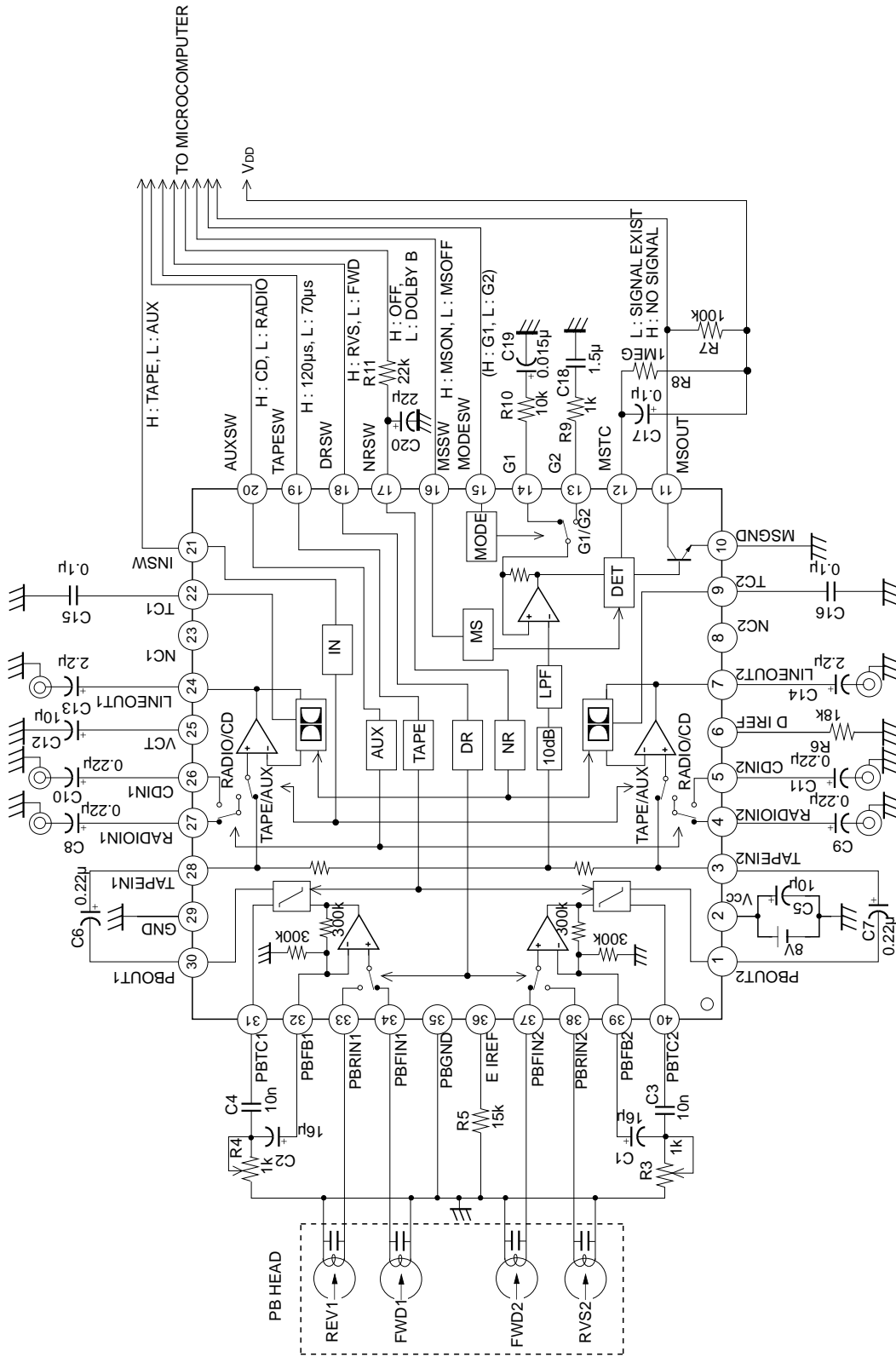

Application circuits shown are typical examples illustrating the operation of the devices. Sony cannot assume responsibility for any problems arising out of the use of these circuits or for any infringement of third party patent and other right due to same.

(1) Signal route

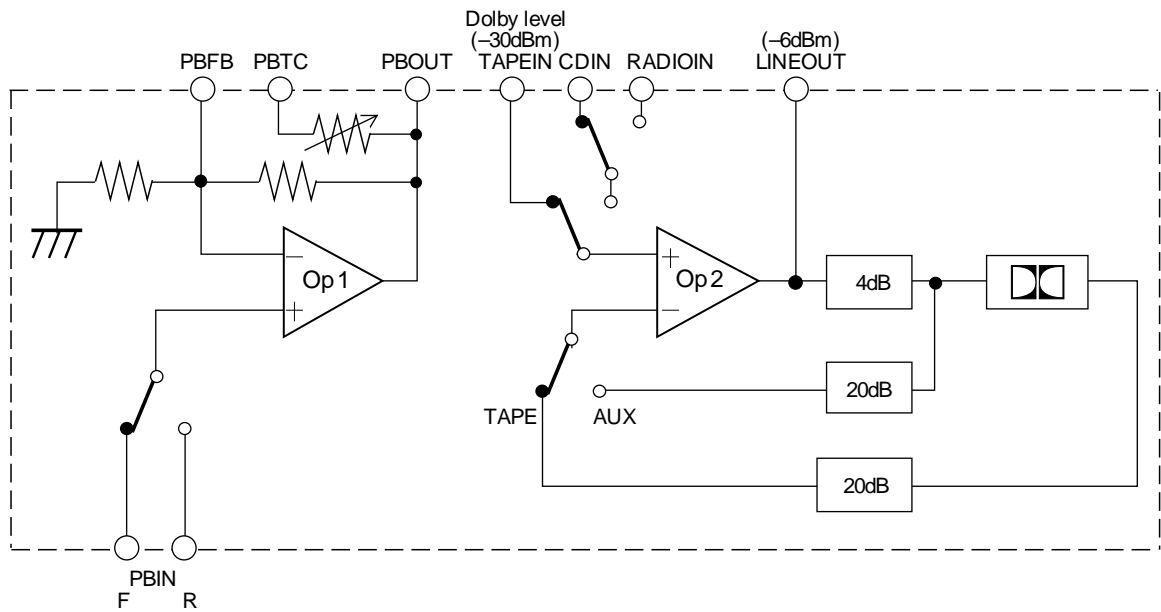

Fig. 1

Op1 and Op2 are operational amplifiers.

Op1 compose the playback equalizer by attaching a resistor and a capacitor to PBFB pin, and a capacitor to PBTC pin.

Op2 is an input selector and a LINEOUT amplifier. The gain of LINEOUT amplifier is 24 dB.

Reference input level for Dolby is -30 dBm.

The adjustment method of playback equalizer is described in the paragraph (3).

(2) Level diagram

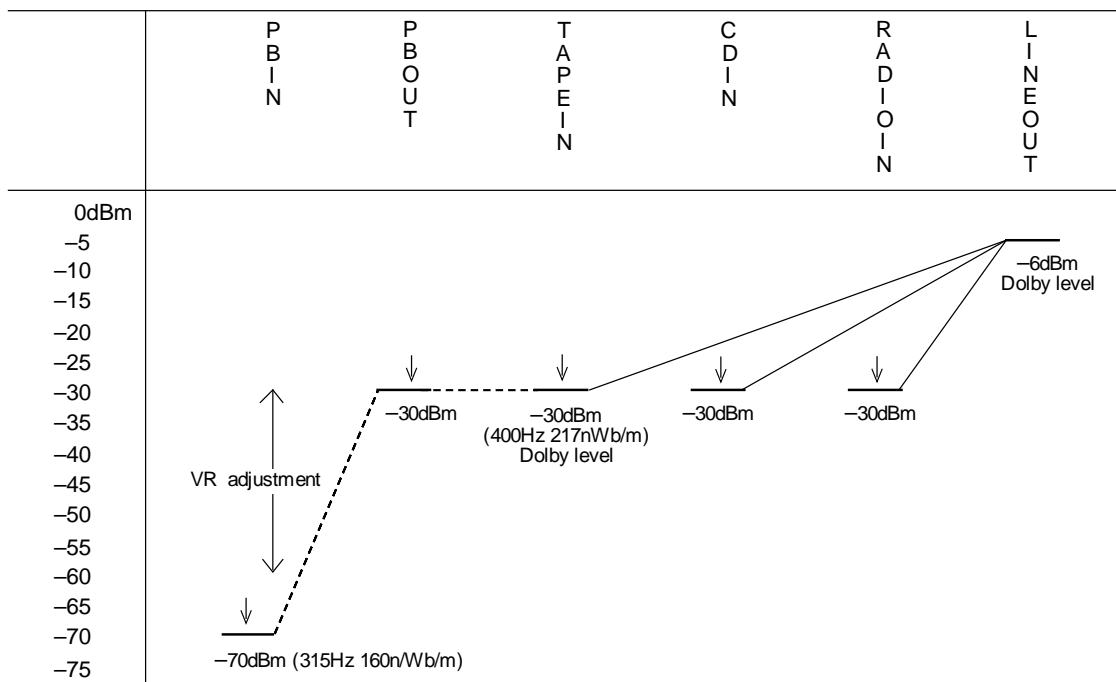

(3) Adjustment of playback equalizer

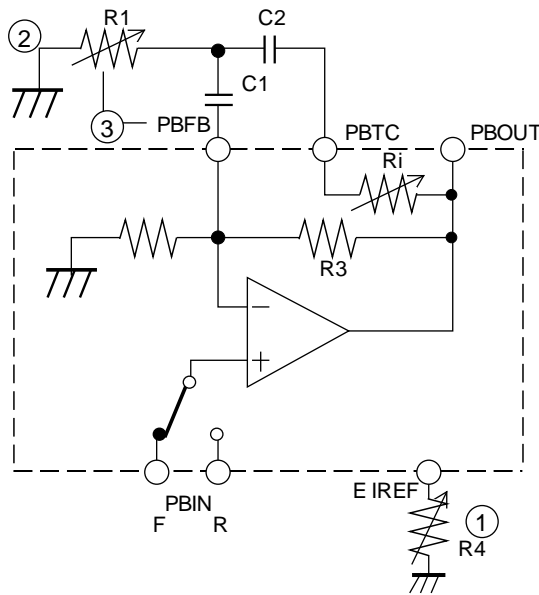

Fig. 3

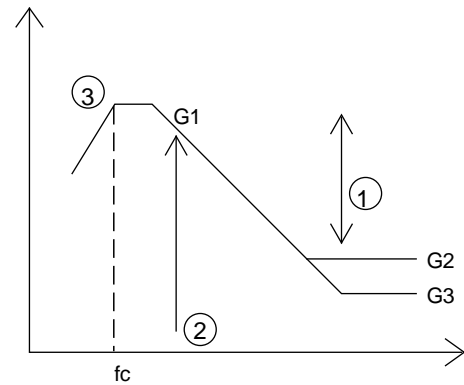

Fig. 4

1) Adjustment of EQ curve gain difference (= adjustment of internal variable R) → E IREF resistor

The internal variable resistor Ri should be adjusted to adjust the EQ curve gain differences (G1-G2), (G1-G3). Therefore, adjust the external resistor R4 for E IREF pin.

2) AC gain adjustment → External resistor R1

The external resistor R1 should be adjusted to adjust the AC gain. G1, G2 and G3 are obtained by the following equations.

$$G1=20\log \frac{R1+R3}{R1} \quad G2=G3=20\log \frac{R1+Ri}{R1}$$

[AC gain can be also adjusted by attaching VR to PBOUT pin, fixing R1. However, the low-band cut-off frequency can be more lowered by R1 adjustment method with the same C1 value used for this method.]

3) Low-band cut-off frequency → External resistor R1 and external capacitor C1

The low-band cut-off frequency (fc) can be determined by the external resistor R1 and external capacitor C1.

(4) MS (interval detection between tracks) adjustment method

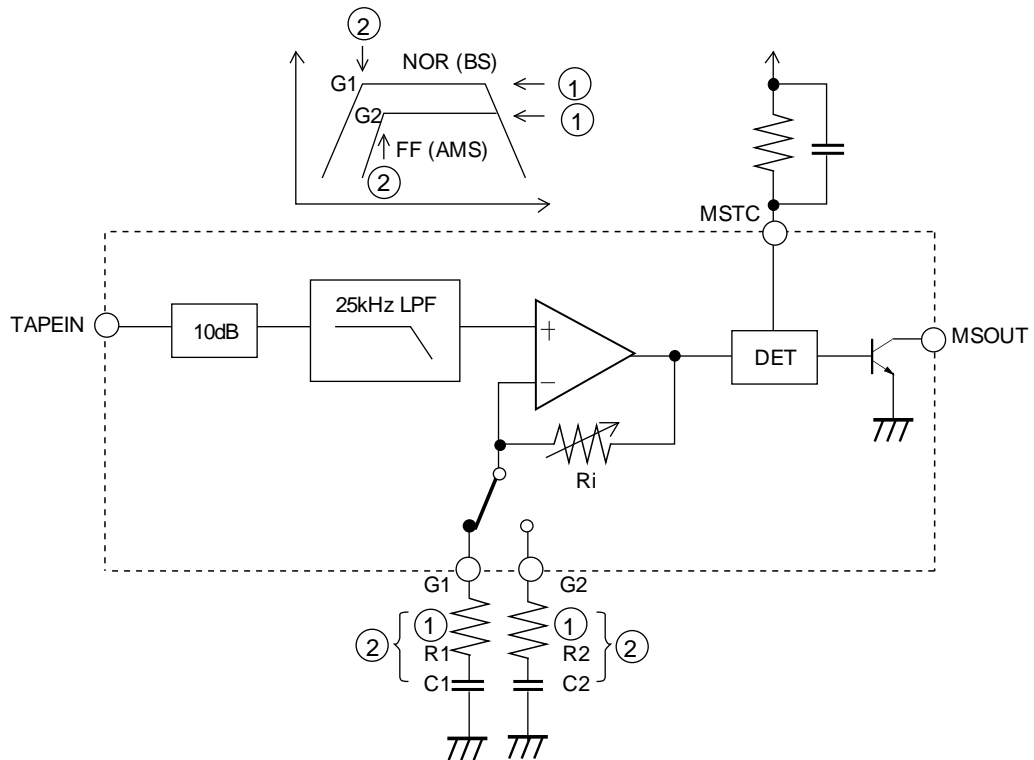

Fig. 5

- 1) MS gain (G1/G2 mode gain) adjustment → External resistors R1, R2  
 MS gain is expressed by the following equations.

$$G1 = 10 + 20 \log \frac{R1 + Ri}{R1} \text{ (dB)} \qquad G2 = 10 + 20 \log \frac{R2 + Ri}{R2} \text{ (dB)}$$

- 2) MS cut-off frequency adjustment → External resistors R1, R2 and external capacitors C1, C2  
 The external resistors R1, R2 and external capacitors C1, C2 should be adjusted to adjust the low-band cut-off frequency of MS frequency characteristics.

Characteristics Graphs

Current consumption vs. Supply voltage  
Ta=25°C

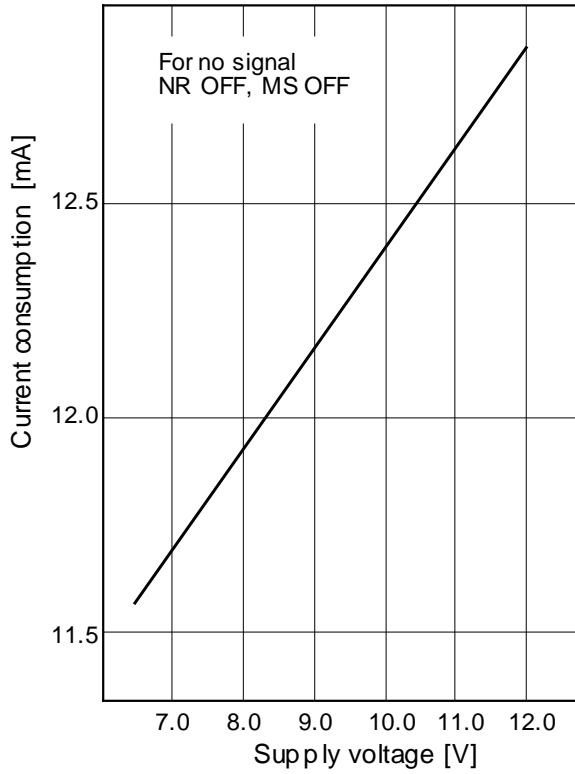

Playback equalizer frequency characteristics  
Ta=25°C

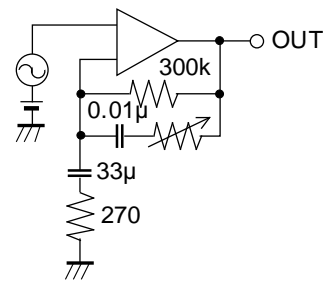
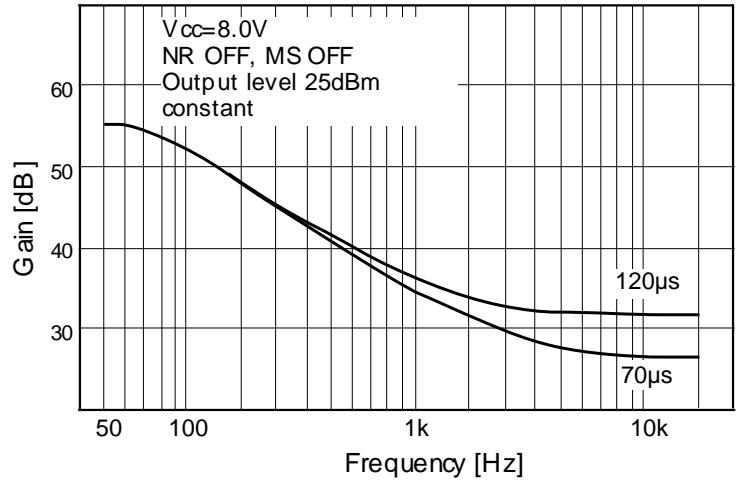

Decode boost frequency characteristics  
Ta=25°C

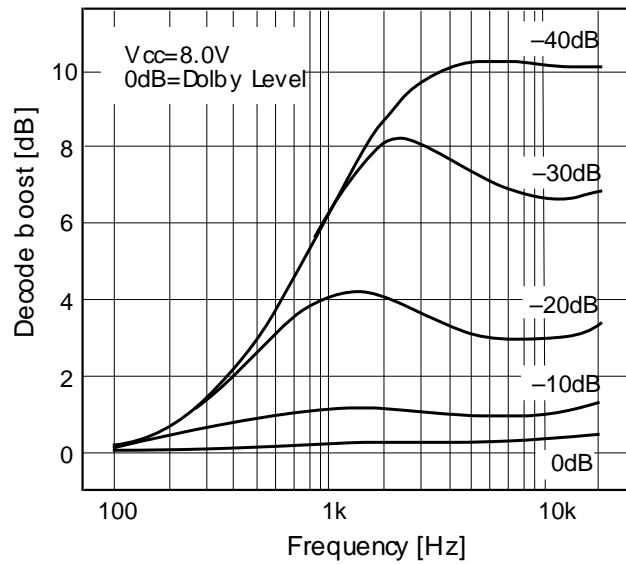

Total harmonic distortion (pre-amplifier block)  
Ta=25°C

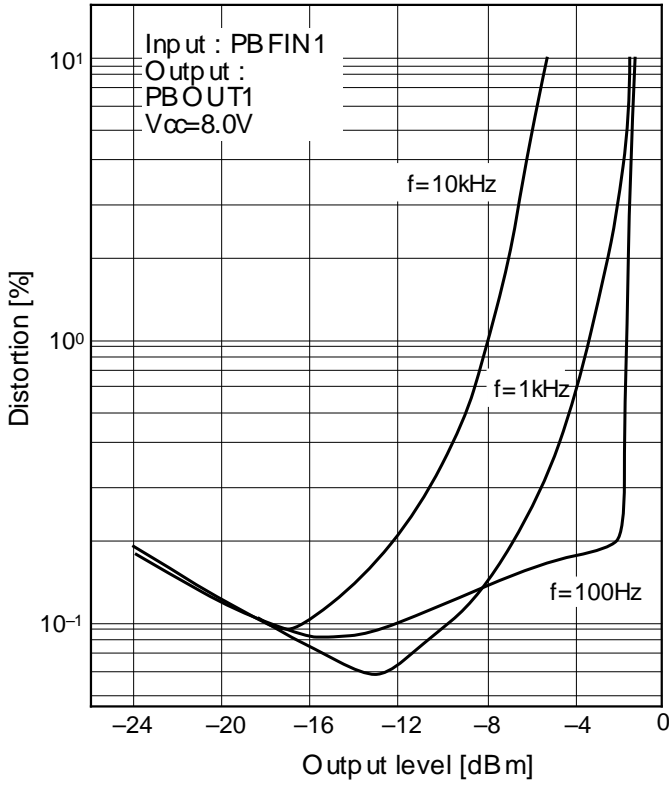

Total harmonic distortion (Dolby block)  
Ta=25°C

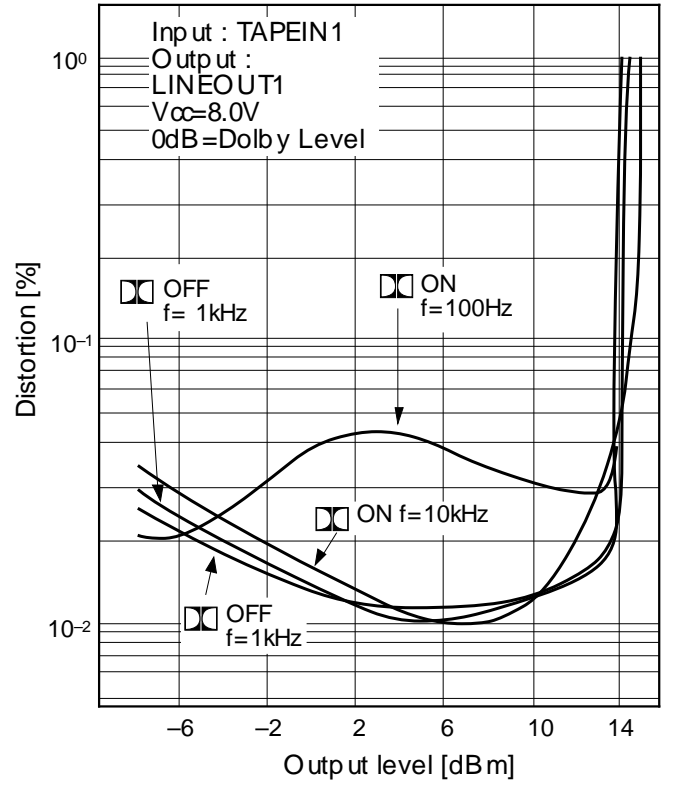

Ripple elimination ratio (PBOUT)  
Ta=25°C

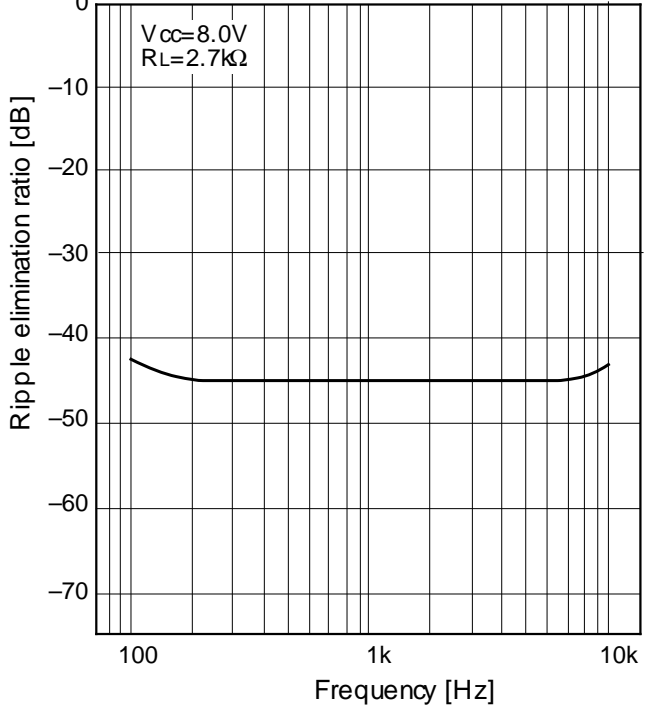

Ripple elimination ratio (LINEOUT)  
Ta=25°C

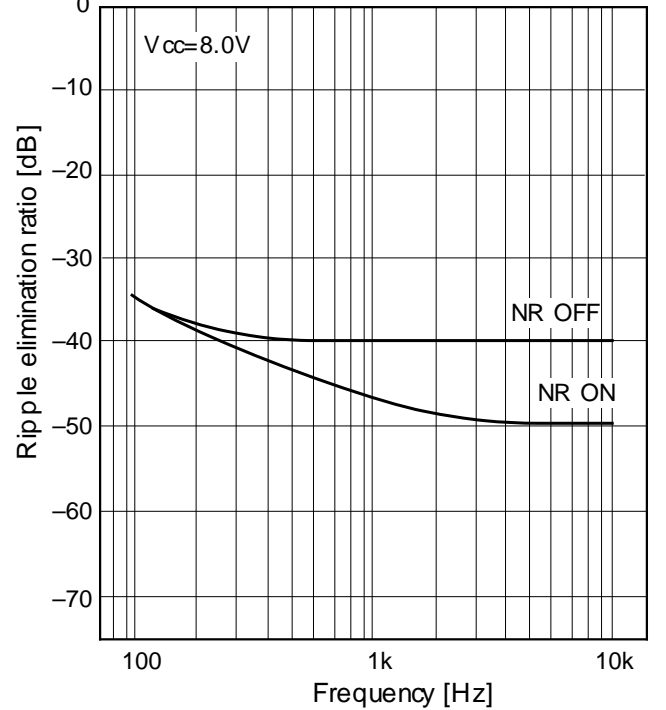

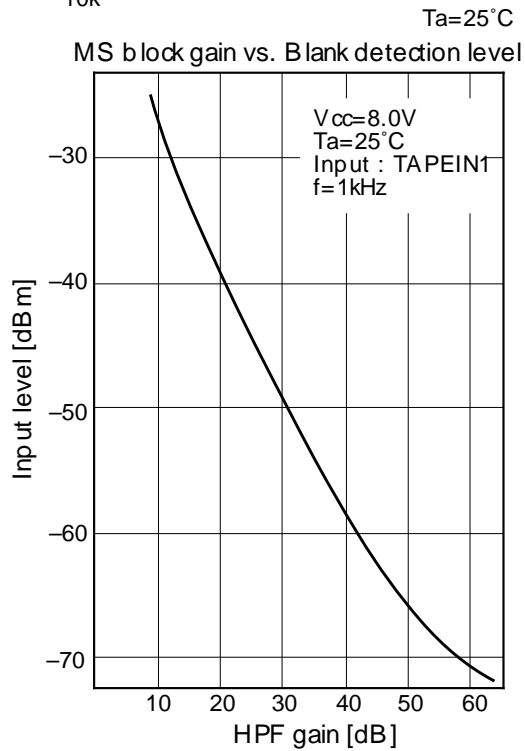
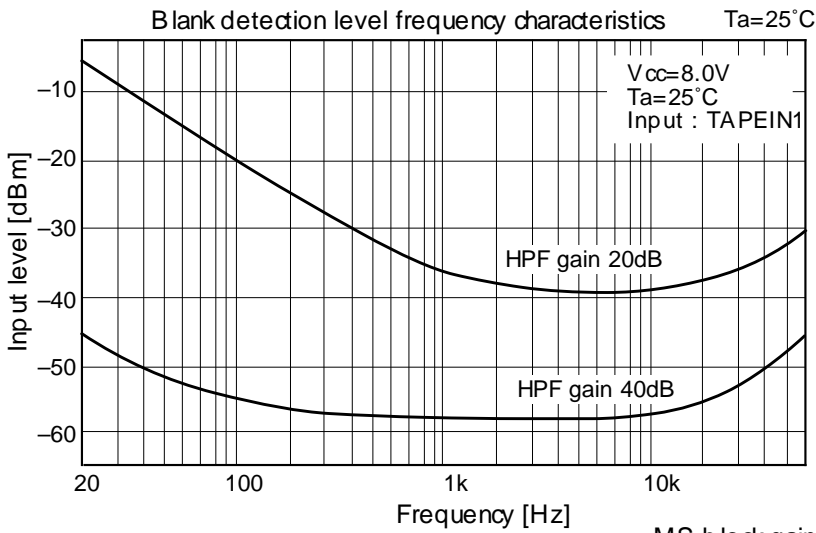
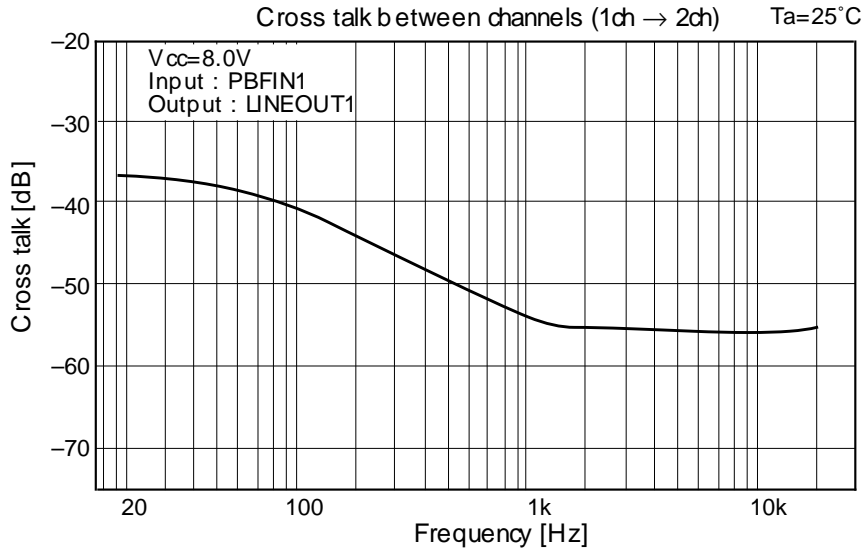



Package Outline Unit : mm

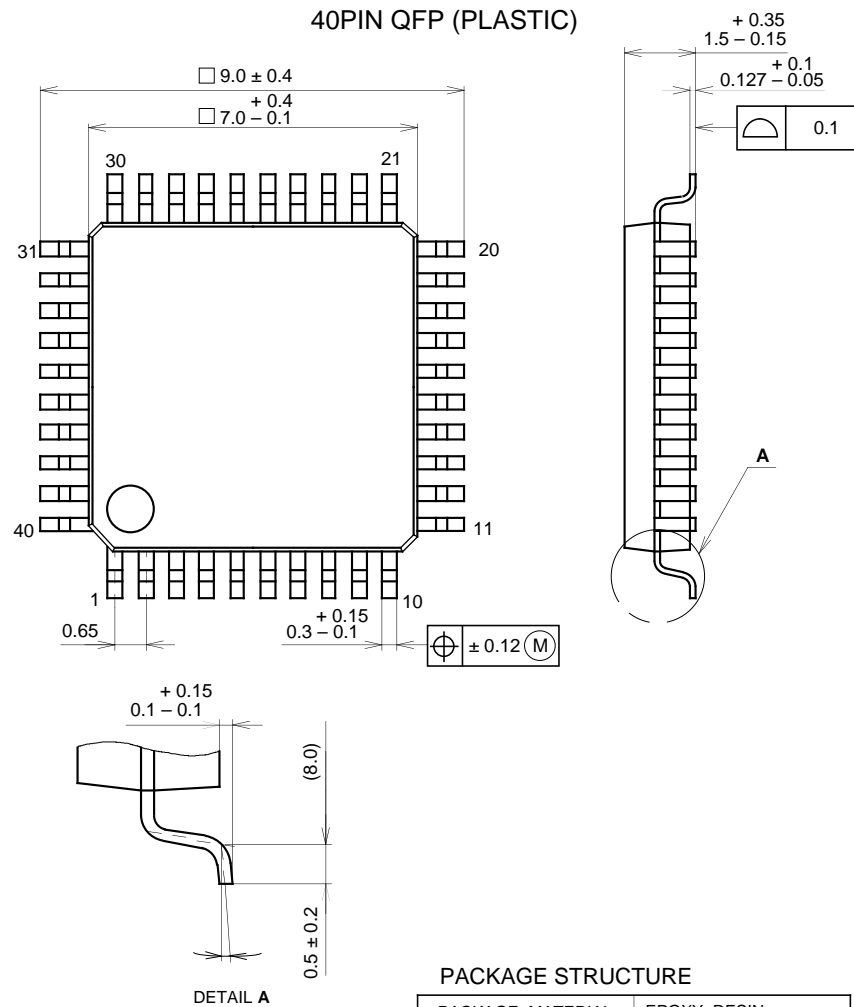

SONY CODE	QFP-40P-L01
EIAJ CODE	*QFP040-P-0707
JEDEC CODE	_____

**PACKAGE STRUCTURE**

PACKAGE MATERIAL	EPOXY RESIN
LEAD TREATMENT	SOLDER / PALLADIUM PLATING
LEAD MATERIAL	COPPER / 42 ALLOY
PACKAGE WEIGHT	0.2g